



REFLEX STEERING STABILIZER **KIT# RBK25**

INSTALLATION INSTRUCTIONS

85-5876-02
12-18

ROADMASTER, Inc. 6110 NE 127th Ave. Vancouver, WA 98682 360-896-0407 fax 360-735-9300 www.roadmasterinc.com

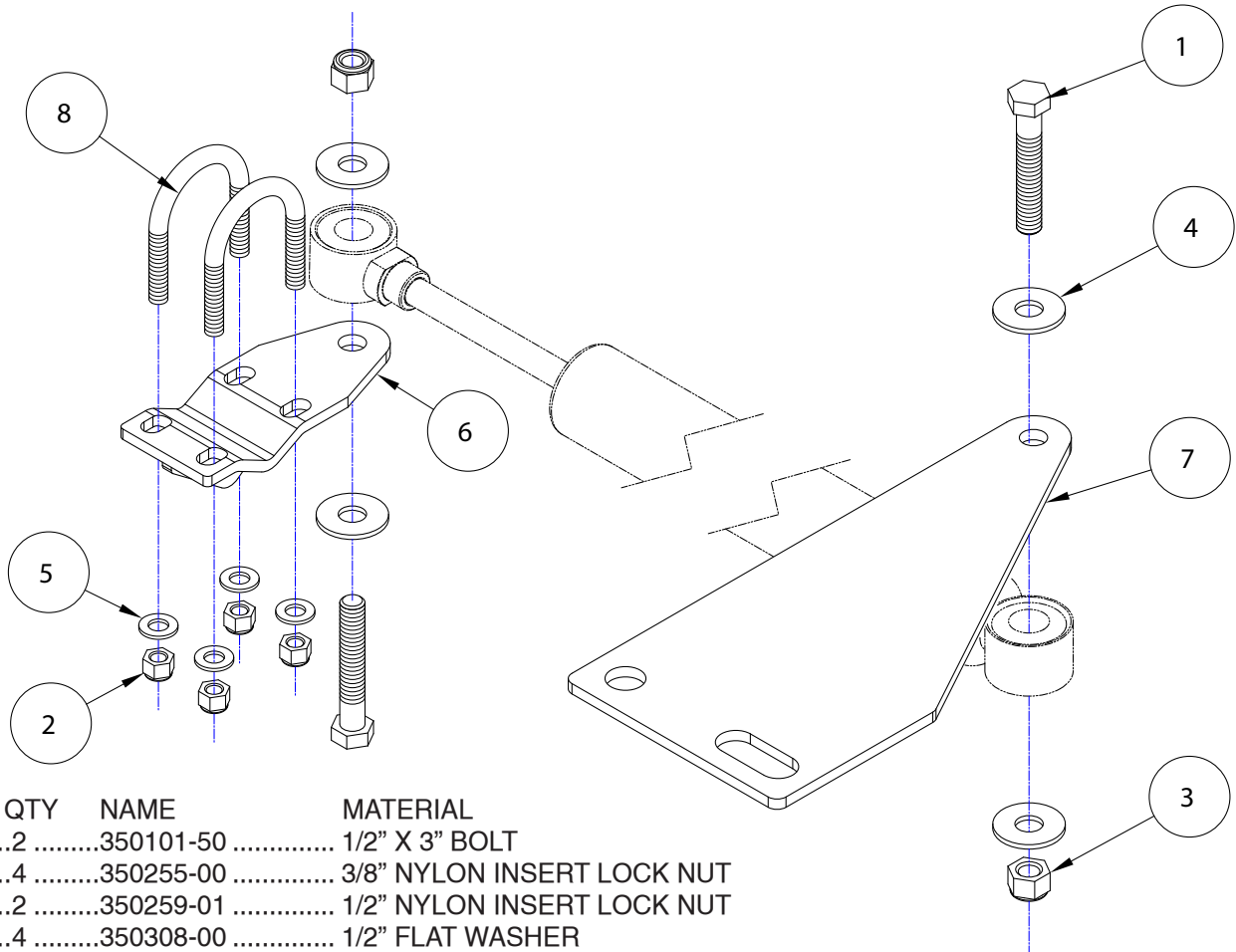

ITEM	QTY	NAME	MATERIAL
1.....2	350101-50	1/2" X 3" BOLT
2.....4	350255-00	3/8" NYLON INSERT LOCK NUT
3.....2	350259-01	1/2" NYLON INSERT LOCK NUT
4.....4	350308-00	1/2" FLAT WASHER
5.....4	355710-00	10MM FLAT WASHER
6.....1	B802	TIE ROD BRACKET
7.....1	B835	BRACKET
8.....2	LRG3	3/8" LARGE U-BOLT

WARNING

Failure to follow these instructions can result in property damage, personal injury or even death.

- The installer must read the instructions and use all bolts and parts supplied. Failure to securely fasten the stabilizer could result in loss of the stabilizer, damage to the vehicle, personal injury or even death.
- There must be adequate clearance between the Reflex Steering Stabilizer and all chassis and steering parts, and any other components, or non-warranty damage to the vehicle will result. After final installation, the installer must inspect the stabilizer to ensure adequate clearance. Some minor adjustments may be needed to achieve this; always verify that the steering wheel remains centered before and after these adjustments.
- Always test drive the vehicle to confirm the steering wheel settings. If the vehicle pulls to either side, the center positioning must be adjusted. If the steering wheel does not return to the center position, the tie rod bracket may require minor adjustments. Failure to adjust the center positioning may result in a loss of vehicular control.
- After installing the Reflex Steering Stabilizer, any technician performing alignment or suspension work on the motorhome must loosen the tie-rod bracket to adjust the toe; the technician must also re-adjust the steering damper. Failure to adjust the center positioning may result in a loss of vehicular control.
- Regardless of year, make and model, a wide range of options for specific applications may or may not interfere with the installation. It is the installer's responsibility to make certain that equipment is not damaged once the suspension solution travels through the full range of motion. Failure to ensure adequate clearance could result in non-warranty property damage, personal injury or even death.
- If running changes were made by the vehicle manufacturer after this kit was designed, some bolts or other fasteners in the included hardware pack may no longer be the correct size. It is the installer's responsibility to verify that the stabilizer is securely fastened to the vehicle, and fitted with the correct hardware, to account for these changes. Failure to securely fasten the stabilizer could result in loss of the stabilizer, damage to the vehicle, personal injury or even death.
- Except to adjust for running changes to the vehicle, use only the parts supplied by ROADMASTER to install the stabilizer. Using substandard grade parts or parts of the wrong size may result in loss of the stabilizer, damage to the vehicle, personal injury or even death.
- Once a year, the owner must inspect the fasteners for proper tightness and/or torque, according to the bolt torque requirements chart in these instructions. Failure to securely fasten the stabilizer could result in loss of the stabilizer, damage to the vehicle, personal injury or even death.
- Do not use an air impact wrench when reinstalling bolts, as stripped threads may result.
- This stabilizer is only warranted for the original installation. Installing a used stabilizer on another vehicle is not recommended and will void the warranty.



REFLEX STEERING STABILIZER KIT# RBK25 INSTALLATION INSTRUCTIONS

85-5876-02
12-18

ROADMASTER, Inc. 6110 NE 127th Ave. Vancouver, WA 98682 360-896-0407 fax 360-735-9300 www.roadmasterinc.com



Fig.1

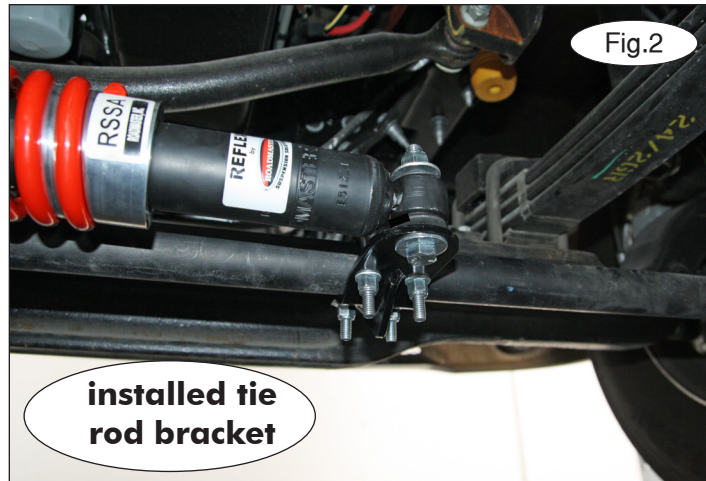

Fig.2

installed tie
rod bracket

Note: Before installing the shock component of this system, please ensure that the spring is fully-seated in its track on the collar of the unit. If it is installed without the spring fully-seated in its track, the unit could malfunction or otherwise fail to operate properly (Fig. 1).

Before beginning the installation, ensure that the front wheels of the vehicle are in the straight-ahead position.

1. Remove the nuts from the rear U-bolt on the driver's side of the front axle.
2. Install the axle bracket B835B over the legs of the U-bolt. Ensure that the gusset on the axle bracket faces down. Tighten the U-bolt nuts evenly. Torque to 250 lb-ft.
3. Attach the tie rod bracket B802 to the tie rod with the gusset pointing down. Place the included 3/8" U-bolts over the top of the tie rod and through the holes in the B802E bracket. Finish with the included washers and 3/8" nylock nuts. Finger-tighten only at this time so that the bracket may be positioned along the tie rod later in the installation process (Fig.2).
4. Place one of the included 1/2" fender washers over a 1/2" x 3" bolt and place the bolt through the mounting hole in the B835 axle bracket. Attach the Reflex shock assembly as shown in Figure 3. Finish with another 1/2" fender washer and 1/2" nylock nut. Finger tighten only at this time.
5. Slide the B802 tie rod bracket into position underneath the other end of the Reflex shock assembly. Place one of the included 1/2" fender washers over a 1/2" x 3" bolt and bolt through the B802E axle bracket and the shock assembly. Finish with a 1/2" fender washer and 1/2" nylock nut.

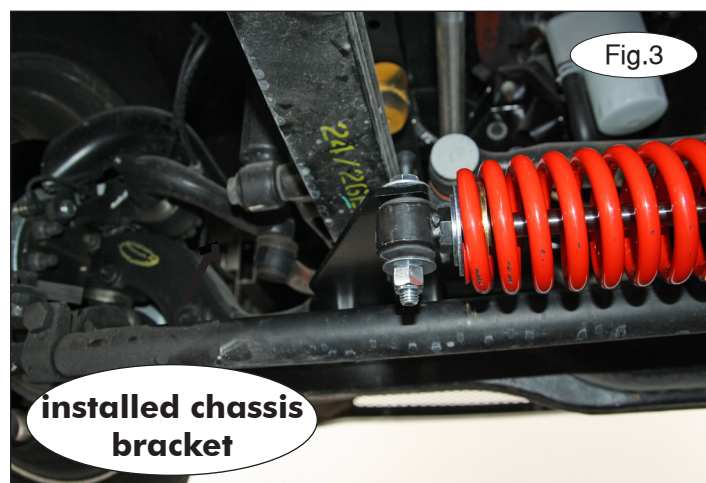

Fig.3

installed chassis
bracket



Fig.4

6. Rotate the B802E tie rod bracket around the tie rod so that it raises the shock to a level position. Tighten the 3/8" U-bolts evenly to 35 lb-ft.
7. Tighten the 1/2" bolts to 25 lb-ft. Figure 4 shows a completed installation.